

VDA 4938 T2 - GLOBAL INVOIC

**BASED ON INVOIC - INVOICE MESSAGE
UN D.07A S3**

Version: V1.2 - 2013
Variant: Gutschrift Vitesco Technologies
Issue date: 05.11.2013
Author: Vitesco Technologies

CONTENTS

1 Message Structure	3
2 Branching Diagram	6
3 Segments.....	13
4 Example	79

Tag	St	MaxOcc	Content	
SG8	O	10	Payment instructions	
PYT	M	1	Payment terms	PYT+1++++D+2'
DTM	O	1	Payment due date	DTM+140:20131128:102'
DTM	O	1	Reference date/time	DTM+171:20131128:102'
PCD	D	1	Discount, payment or instalment percentage	PCD+7:5'
MOA	O	1	Instalment or payment discount amount	MOA+52:67:EUR'
MOA	D	1	Monetary amount	MOA+372:9:EUR'
PAI	D	1	Payment instructions	PAI+::49'
FII	O	1	Financial institution information	FII+RH+4433221100:Iron Parts Ltd.:Kont oinhaber2+:::10090000::131:Volksbank'
SG26	R	900	Line item section	
LIN	M	1	Line item and article nubner	LIN+1++1234:IN'
PIA	O	1	Additional article identifier(s) 1	PIA+1+9876:SA'
IMD	R	5	Description of article or service	IMD+++:::Article description'
QTY	R	1	Invoiced quantity	QTY+47:9:C62'
ALI	O	1	Country of origin, customs information and booking key	ALI++N+67'
DTM	D	1	Delivery or service completion date	DTM+1:20100308:102'
FTX	O	99	Tax exemption reason text	FTX+TXD+++X:X:X:X+aa'
SG27	R	1	Line item net amount	
MOA	M	1	Line item net amount in invoice currency	MOA+203:9:EUR'
SG29	O	1	Calculation gross price	
PRI	M	1	Price details	PRI+AAB:9::AAL::KGM'
SG30	O	1	Frame contract (blanket order) / Order / Purchase order	
RFF	M	1	Frame contract (blanket order) / Order / Purchase order	RFF+ON:Bestellnummer:1'
SG30	O	1	Despatch note / delivery note (synonym)	
RFF	M	1	Reference message number	RFF+AAU:Lieferscheinnummer:1'
DTM	O	1	Reference message date	DTM+171:20131120:102'
SG30	O	1	Goods receipt number / consignment withdeawal or aggregation number	
RFF	M	1	Reference message number	RFF+ALO:Wareneingangsnummer:5'
SG30	O	1	internal-order-number	
RFF	M	1	Reference message number	RFF+IL:Abrechnungslieferplannummer:5'
SG34	R	1	VAT rate and amount for line item	
TAX	M	1	VAT or other tax rate	TAX+7+VAT+++:::19+AA'
UNS	M	1	Section control	UNS+S'
SG50	R	3	Invoice amount	
MOA	M	1	Invoice amount	MOA+77:1000:EUR'
SG50	R	3	Total tax amount	
MOA	M	1	Total tax amount	MOA+176:9:EUR'
SG50	O	3	Total line items amount	
MOA	M	1	Total line items amount (sum of net line items amounts)	MOA+79:9:EUR'
SG52	R	10	Tax rates and amounts	
TAX	M	1	Tax type and rate	TAX+7+VAT+++:::19+S'

MaxOcc = Maximum occurrence of the segment/
group

St = Status: M=Mandatory, C=Conditional, R=Required, O=Optional,
D=Dependent, A=Advised, N=Not used

Tag	St	MaxOcc	Content	
MOA	R	1	Taxable amount in invoice currency	MOA+125:9:EUR'
SG53	D	15	Delivery costs	
ALC	M	1	Charge	ALC+C++++ABK: :272'
MOA	R	1	Charge amount	MOA+8:9:EUR'
FTX	O	1	Charge description text	FTX+ALC+++X:X:X:X:en'
UNT	M	1	Message trailer	UNT+55+1'
UNZ	M	1	Interchange trailer	UNZ+1+144659'

MaxOcc = Maximum occurrence of the segment/
 group

St = Status: M=Mandatory, C=Conditional, R=Required, O=Optional,
 D=Dependent, A=Advised, N=Not used

2. BRANCHING DIAGRAM OF USED SEGMENTS/GROUPS

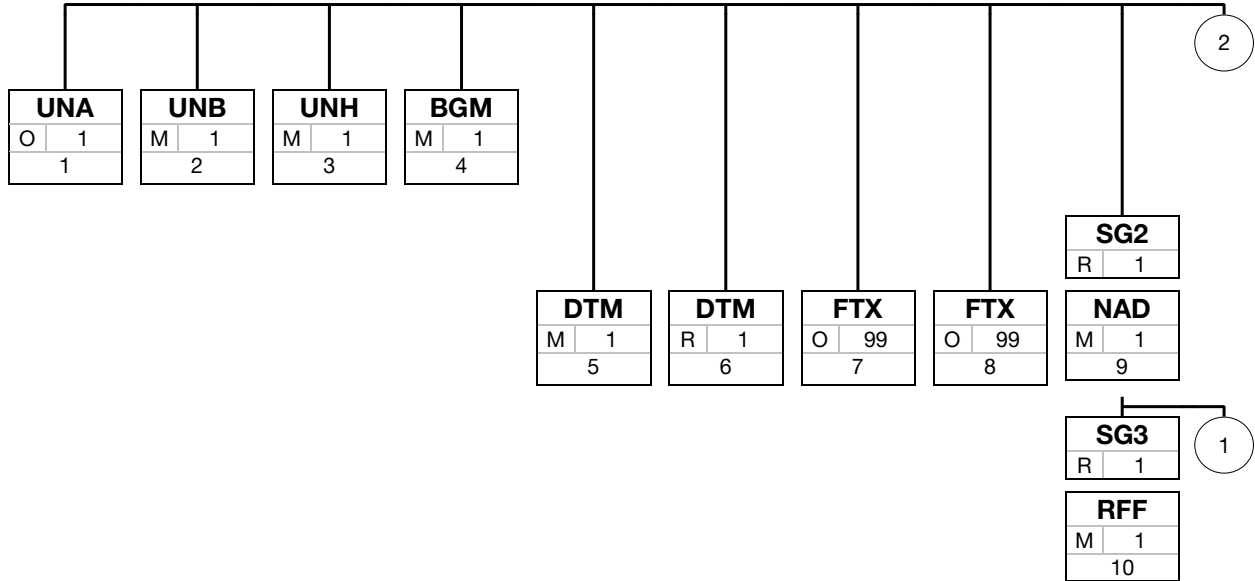

Tag
St MaxOcc
No

Tag = Segment/Group Tag
St = Status: M=Mandatory, C=Conditional, R=Required, O=Optional, D=Dependent, A=Advised, N=Not used
MaxOcc = Maximum occurrence of the segment/group
No = Consecutive segment number

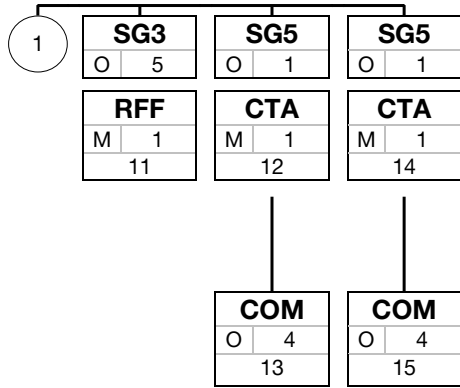

Tag
St MaxOcc
No

Tag = Segment/Group Tag
 St = Status: M=Mandatory, C=Conditional, R=Required, O=Optional, D=Dependent, A=Advised, N=Not used
 MaxOcc = Maximum occurrence of the segment/group
 No = Consecutive segment number

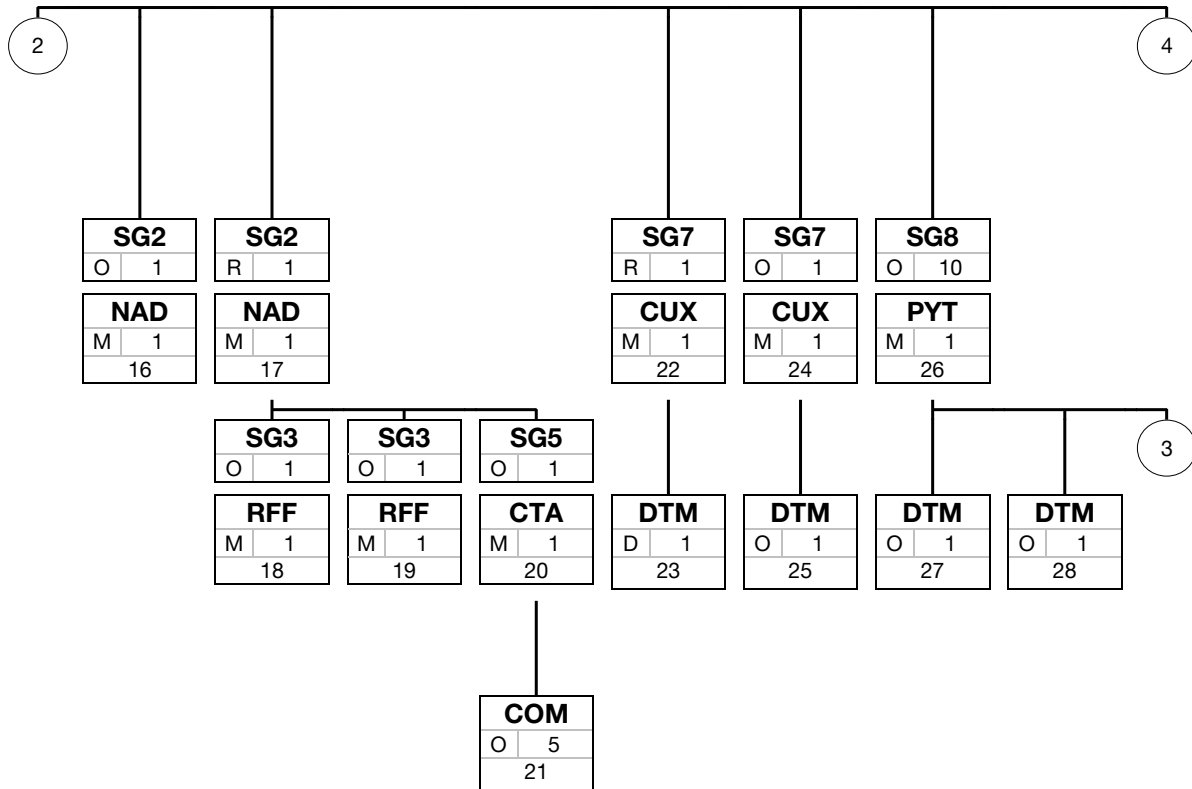

Tag	
St	MaxOcc
No	

Tag = Segment/Group Tag
 St = Status: M=Mandatory, C=Conditional, R=Required, O=Optional, D=Dependent, A=Advised, N=Not used
 MaxOcc = Maximum occurrence of the segment/group
 No = Consecutive segment number

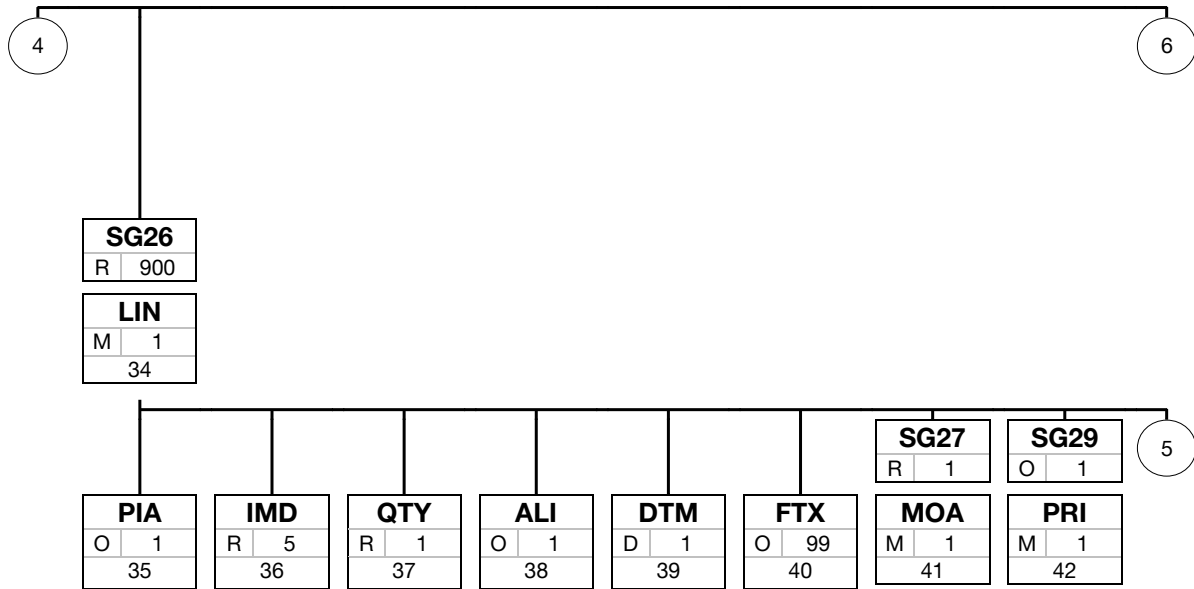

Tag	
St	MaxOcc
No	

Tag = Segment/Group Tag
 St = Status: M=Mandatory, C=Conditional, R=Required, O=Optional, D=Dependent, A=Advised, N=Not used
 MaxOcc = Maximum occurrence of the segment/group
 No = Consecutive segment number

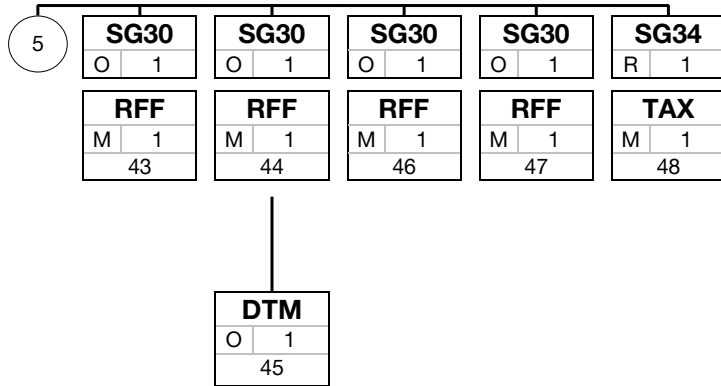

Tag
St MaxOcc
No

Tag = Segment/Group Tag
 St = Status: M=Mandatory, C=Conditional, R=Required, O=Optional, D=Dependent, A=Advised, N=Not used
 MaxOcc = Maximum occurrence of the segment/group
 No = Consecutive segment number

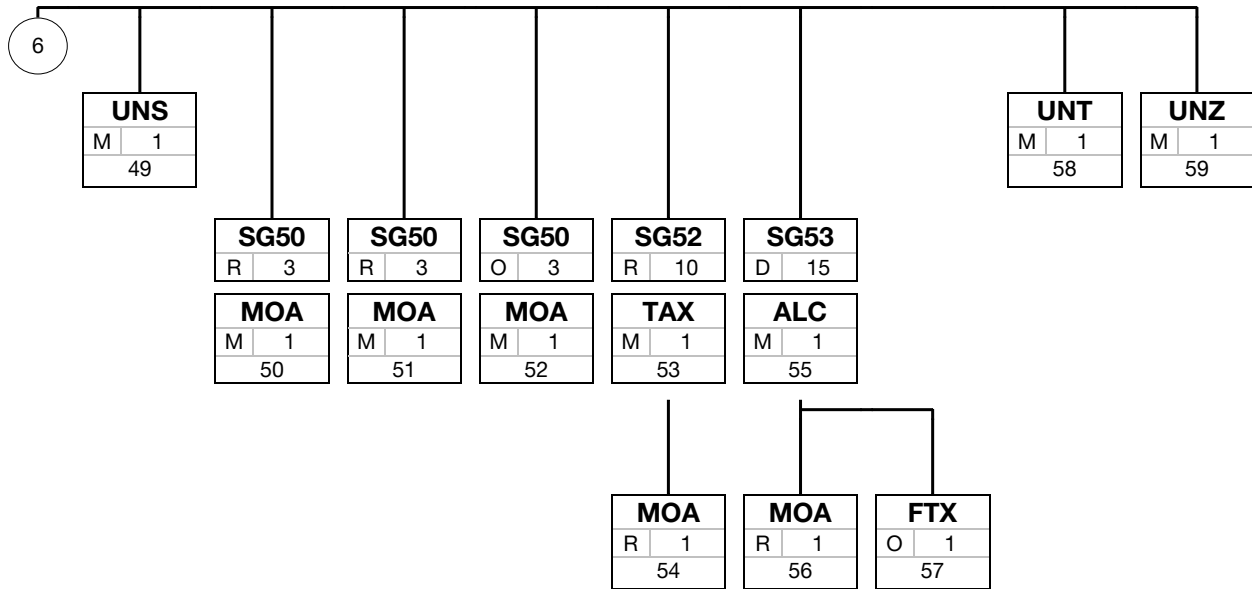

Tag
St MaxOcc
No

Tag = Segment/Group Tag
St = Status: M=Mandatory, C=Conditional, R=Required, O=Optional, D=Dependent, A=Advised, N=Not used
MaxOcc = Maximum occurrence of the segment/group
No = Consecutive segment number

3. SEGMENTS

Tag	St	MaxOcc	Name	
UNA	O	1	Service string advice	
		EDIFACT	vitesco	
Tag	Name	St Format	St Format	Usage / Remark
UNA1	Component data element separator	M an1	M an1	Colon
UNA2	Data element separator	M an1	M an1	Plus sign
UNA3	Decimal notation	M an1	M an1	Point
UNA4	Release indicator	M an1	M an1	Question mark
UNA5	Reserved for future use	M an1	M an1	Blank
UNA6	Segment terminator	M an1	M an1	Apostrophe

Remark:

Example: UNA:+. ? '

3. SEGMENTS

Tag	St	MaxOcc	Name			
UNB	M	1	Interchange header			
EDIFACT			vitesco			
Tag	Name	St	Format	St	Format	Usage / Remark
S001	Syntax identifier	M		M		
0001	Syntax identifier	M	a4	M	a4	UNOC UN/ECE level C
0002	Syntax version number	M	n1	M	n1	3 Version 3
S002	Interchange sender	M		M		
0004	Sender identification	M	an..35	M	an..35	Unique ID of the sender in the data transmission network or system.
0007	Partner identification code qualifier	C	an..4	O	an..4	
0008	Address for reverse routing	C	an..14	O	an..14	Address of an application or internal system at sender's site to which answer messages should be routed.
S003	Interchange recipient	M		M		
0010	Recipient identification	M	an..35	M	an..35	Unique ID of the receiver in the data transmission network or system.
0007	Partner identification code qualifier	C	an..4	O	an..4	
0014	Routing address	C	an..14	O	an..14	Address of an application or internal system at recipient's site.
S004	Date/time of preparation	M		M		
0017	Date of preparation	M	n6	M	n6	Format YYMMDD
0019	Time of preparation	M	n4	M	n4	Format HHMM
0020	Interchange control reference	M	an..14	M	an..14	Unique ID of an interchange.
S005	Recipient's reference, password			N		
0022	Recipient's reference/ password		an..14	N		Not used
0025	Recipient's reference/ password qualifier		an2	N		Not used
0026	Application reference		an..14	N		Not used
0029	Processing priority code		a1	N		Not used
0031	Acknowledgement request		n1	N		Not used
0032	Communications agreement ID		an..35	N		Not used
0035	Test indicator	C	n1	O	n1	1 Interchange is a test Only to be used, if the interchange is for test purposes. Omit this data element for valid interchanges.

Remark:

Example: UNB+UNOC:3+OD012345:59:123+987654321:1:X+071205:1446+144659+++++1'

MaxOcc = Maximum occurrence of the segment/group; St = Status: M=Mandatory, C=Conditional, R=Required, O=Optional, D=Dependent, A=Advised, N=Not used

3. SEGMENTS

Tag	St	MaxOcc	Name			
UNH	M	1	Message header			
			EDIFACT	vitesco		
Tag	Name	St	Format	St	Format	Usage / Remark
0062	Message reference number	M	an..14	M	an..14	Message reference number - unique number to identify the message within the interchange, usually a consecutive number starting with 1.
S009	Message identifier	M		M		
0065	Message type	M	an..6	M	an..6	INVOIC Invoice message
0052	Message version number	M	an..3	M	an..3	D Draft version/UN/EDIFACT Directory
0054	Message release number	M	an..3	M	an..3	07A Release 2007 - A
0051	Controlling agency	M	an..2	M	an..2	UN UN/CEFACT
0057	Association assigned code	C	an6	R	an6	Identification of the subset release, assigned by the responsible organisation (Odette or member organisation). The code assigned by VDA should be used for a more exact specification of the applied subset.
0068	Common access reference		an..35	N		Not used
S010	Status of the transfer			N		
0070	Sequence of transfers		n..2	N		Not used
0073	First and last transfer		a1	N		Not used

Remark:

Example: UNH+1+INVOIC:D:07A:UN:GAVA12'

3. SEGMENTS

Tag	St	MaxOcc	Name			
BGM	M	1	Type of invoice and invoice number			
EDIFACT			vitesco			
Tag	Name	St	Format	St	Format	Usage / Remark
C002	Document/message name	C		R		
1001	Document name code	C	an..3	R	an..3	The following explanations are intended to support a unique usage of the different message types: Table of transaction types and their results Code specifying the type or subtype of the business document. Use UN/EDIFACT code list 1001 and JAI code list JAI001 389 Self-billed invoice
1131	Code list identification code		an..17	N		Not used
3055	Code list responsible agency code	C	an..3	O	an..3	272 Joint Automotive Industry agency Agency responsible for code list / identifier maintenance
1000	Document name	C	an..35	O	an..35	Name of the document in text
C106	Document/message identification	C		R		
1004	Document identifier	C	an..16	R	an..16	Invoice number
1056	Version identifier		an..9	N		Not used
1060	Revision identifier		an..6	N		Not used
1225	Message function code	C	an..3	O	an..3	9 Original 7 Duplicate Code indicating the function of the document.
4343	Response type code		an..3	N		Not used

Remark:

Example: BGM+389:::Gutschrift+Rechnungsnummer+9'

3. SEGMENTS

Tag	St	MaxOcc	Name	
DTM	M	1	Message date	
EDIFACT		vitesco		
Tag	Name	St Format	St Format	Usage / Remark
C507	Date/time/period	M	M	
2005	Date or time or period function code qualifier	M an..3	M an..3	The message date is perceived as synonym also for the invoice date. 137 Document issue date time
2380	Date or time or period text	C n8	R n8	Date of the invoice document
2379	Date or time or period format code	C an..3	R an..3	102 CCYYMMDD

Remark:

Example: DTM+137:20131126:102'

MaxOcc = Maximum occurrence of the segment/group; St = Status: M=Mandatory, C=Conditional, R=Required, O=Optional, D=Dependent, A=Advised, N=Not used

3. SEGMENTS

Tag	St	MaxOcc	Name			
DTM	R	1	Delivery or Service Completion Date			
EDIFACT			vitesco			
Tag	Name	St	Format	St	Format	Usage / Remark
C507	Date/time/period	M		M		
2005	Date or time or period function code qualifier	M	an..3	M	an..3	1 Service completion date/time, actual
2380	Date or time or period text	C	n..12	R	n..12	Service completion date
2379	Date or time or period format code	C	an..3	R	an..3	102 CCYYMMDD

Remark:

In Europe, the invoice must contain the delivery or service date that is relevant for taxation purposes. Depending on the business process this can be the shipment date, the arrival date (receiving date) or even the consumption date. This segment is to be used to have one unique date that is not dependent on the individual process.

If an invoice contains line items with different tax rates for the same tax type (for instance the standard tax rate increases from 19% in month A to 21% in month B and the invoice covers line items of month A and B) then the allocation of tax amounts related to the different tax rates in the summary section and their allocation to different tax periods in the accounting system has to be done independently of the delivery or service completion date in the header.

Example: DTM+1:20100308:102'

3. SEGMENTS

Tag	St	MaxOcc	Name			
FTX	O	99	Legal info free text			
			EDIFACT	vitesco		
Tag	Name	St	Format	St	Format	Usage / Remark
4451	Text subject code qualifier	M	an..3	M	an..3	REG Regulatory information REG is to be used for information required by legislation (e.g. members of the board etc.).
4453	Free text function code		an..3	N		Not used
C107	Text reference			N		
4441	Free text description code		an..17	N		Not used
1131	Code list identification code		an..17	N		Not used
3055	Code list responsible agency code		an..3	N		Not used
C108	Text literal	C		R		
4440	Free text	M	an..256	M	an..256	A line of plain, non-structured text information.
4440	Free text	C	an..256	O	an..256	see 4440 # 1
4440	Free text	C	an..256	O	an..256	see 4440 # 1
4440	Free text	C	an..256	O	an..256	see 4440 # 1
4440	Free text	C	an..256	O	an..256	see 4440 # 1
3453	Language name code	C	an..3	O	an..3	Code specifying the language name. Use ISO 639-1988
4447	Free text format code		an..3	N		Not used

Remark:

Free text containing information or statements as required by legal environment.

Example: FTX+REG+++Gutschrift:Text:Text:Text:Text+de'

3. SEGMENTS

Tag	St	MaxOcc	Name			
FTX	O	99	Legal info free text			
			EDIFACT	vitesco		
Tag	Name	St	Format	St	Format	Usage / Remark
4451	Text subject code qualifier	M	an..3	M	an..3	TXD Tax declaration TXD is to be used for declaring the reason for tax exemption, valid for all line items.
4453	Free text function code		an..3	N		Not used
C107	Text reference			N		
4441	Free text description code		an..17	N		Not used
1131	Code list identification code		an..17	N		Not used
3055	Code list responsible agency code		an..3	N		Not used
C108	Text literal	C		R		
4440	Free text	M	an..256	M	an..256	A line of plain, non-structured text information.
4440	Free text	C	an..256	O	an..256	see 4440 # 1
4440	Free text	C	an..256	O	an..256	see 4440 # 1
4440	Free text	C	an..256	O	an..256	see 4440 # 1
4440	Free text	C	an..256	O	an..256	see 4440 # 1
3453	Language name code	C	an..3	O	an..3	Code specifying the language name. Use ISO 639-1988
4447	Free text format code		an..3	N		Not used

Remark:

Free text containing information or statements as required by legal environment.

Example: FTX+TXD+++Text:Text:Text:Text:Text+de '

3. SEGMENTS

Tag	St	MaxOcc	Name			
SG2	R	1	Buyer			
NAD	M	1	Buyer's Name and Address			
			EDIFACT	vitesco		
Tag	Name	St	Format	St	Format	Usage / Remark
3035	Party function code qualifier	M	an..3	M	an..3	BY Buyer
C082	Party identification details	C		R		All partners listed in the invoicing message are to be transmitted with the complete name and address information. Partner ID is an additional information for enabling the automated processing and matching to internal records.
3039	Party identifier	M	an..35	M	an..35	Unique identification of a party by an ID (customer number, supplier number, DUNS or similar).
1131	Code list identification code		an..17	N		Not used
3055	Code list responsible agency code	C	an..3	R	an..3	91 Assigned by seller or seller's agent Agency responsible for code list / identifier maintenance
C058	Name and address	C		O		
3124	Name and address description	M	an..35	M	an..35	
3124	Name and address description		an..35	N		Not used
3124	Name and address description		an..35	N		Not used
3124	Name and address description		an..35	N		Not used
3124	Name and address description		an..35	N		Not used
C080	Party name	C		O		
3036	Party name	M	an..35	M	an..35	Single text line for specification of a name
3036	Party name	C	an..35	O	an..35	see 3036 # 1
3036	Party name	C	an..35	O	an..35	see 3036 # 1
3036	Party name	C	an..35	O	an..35	see 3036 # 1
3036	Party name		an..35	N		Not used
3045	Party name format code		an..3	N		Not used
C059	Street	C		O		
3042	Street and number or post office box identifier	M	an..35	M	an..35	The name that identifies the location of a house or building: usually within a street as part of an address.
3042	Street and number or post office box identifier	C	an..35	O	an..35	see 3042 # 1
3042	Street and number or post office box identifier		an..35	N		Not used
3042	Street and number or post office box identifier		an..35	N		Not used
3164	City name	C	an..35	R	an..35	The name of the city, town, or village of this address.
C819	Country subdivision details			N		

MaxOcc = Maximum occurrence of the segment/group; St = Status: M=Mandatory, C=Conditional, R=Required, O=Optional, D=Dependent, A=Advised, N=Not used

EDIFACT			vitesco		
Tag	Name	St Format	St	Format	Usage / Remark
3229	Country subdivision identifier	an..9	N		Not used
1131	Code list identification code	an..17	N		Not used
3055	Code list responsible agency code	an..3	N		Not used
3228	Country subdivision name	an..70	N		Not used
3251	Postal identification code	C an..17	R	an..17	The identifier for one or more properties according to the postal service of that country; a group of letters and/or numbers added to the postal address to assist in the sorting of mail.
3207	Country identifier	C a2	R	a2	Provides the country part of an address using a code. Use ISO3166 two alpha code.

Remark:

Party to whom merchandise and/or service is sold.

Example: NAD+BY+Identifier::91+Name+Name:Name:Name:Name+Strasse:Strasse+Ort++PLZ+DE'

3. SEGMENTS

Tag	St	MaxOcc	Name
SG3	R	1	Buyer's VAT reference number
RFF	M	1	Buyer's reference number(s)
		EDIFACT	vitesco
Tag	Name	St Format	St Format Usage / Remark
C506	Reference	M	M
1153	Reference code qualifier	M an..3	M an..3
1154	Reference identifier	C an..35	R an..35
1156	Document line identifier	an..6	N
1056	Version identifier	an..9	N
1060	Revision identifier	an..6	N

Remark:

Example: RFF+VA:7656444'

MaxOcc = Maximum occurrence of the segment/group; St = Status: M=Mandatory, C=Conditional, R=Required, O=Optional, D=Dependent, A=Advised, N=Not used

3. SEGMENTS

Tag	St	MaxOcc	Name	
SG3	O	5	Buyer's reference number(s)	
RFF	M	1	Buyer's reference number(s)	
EDIFACT		vitesco		
Tag	Name	St Format	St Format Usage / Remark	
C506	Reference	M	M	
1153	Reference code qualifier	M an..3	M an..3	<p>ANK may be used to transmit the DUNS number in addition to customer or supplier number in the NAD segment. This is only necessary if both numbers have to be transmitted. If only the DUNS number is required, the the NAD DE 3019 shall be used.</p> <p>ADE Account number ANK Reference number assigned by third party FC Fiscal number XA Company/place registration number</p>
1154	Reference identifier	C an..35	R an..35	<p>For 1153=ADE: The account ID of a party, allocated by a trading partner for the debits or credits account used within the internal information processing and financial system. There is not always a one to one relationship between this number and the party's identification number.</p> <p>For 1153=FC: Tax payer's number. Number assigned to individual persons as well as to corporates by a public institution; this number is different from the VAT registration number.</p> <p>For 1153=VA: Unique number assigned by the relevant tax authority to identify a party for use in relation to Value Added Tax (VAT).</p> <p>For 1153=XA: Identifier of a company in the commercial registry</p>
1156	Document line identifier	an..6	N	Not used
1056	Version identifier	an..9	N	Not used
1060	Revision identifier	an..6	N	Not used

Remark:

Example: RFF+ADE:7656444'

MaxOcc = Maximum occurrence of the segment/group; St = Status: M=Mandatory, C=Conditional, R=Required, O=Optional, D=Dependent, A=Advised, N=Not used

3. SEGMENTS

Tag	St	MaxOcc	Name			
SG5	O	1	Information contact			
CTA	M	1	Contact information			
EDIFACT			vitesco			
Tag	Name	St	Format	St	Format	Usage / Remark
3139	Contact function code	C	an..3	R	an..3	IC Information contact
C056	Contact details	C		O		
3413	Contact identifier	C	an..17	O	an..17	Identifies the department or employee by a unique identifier other than their name when given as a contact.
3412	Contact name	C	an..35	O	an..35	Name of the contact person or department

Remark:

Example: CTA+IC+X:X'

3. SEGMENTS

Tag	St	MaxOcc	Name	
SG5	O	1	Information contact	
COM	O	4	Communication contact	
EDIFACT			vitesco	
Tag	Name	St Format	St Format	Usage / Remark
C076	Communication contact	M	M	
3148	Communication address identifier	M an..100	M an..100	Buyer's Communication Number
3155	Communication means type code	M an..3	M an..3	EM Electronic mail FX Telefax IM Internal mail TE Telephone

Remark:

Example: COM+X:TE'

3. SEGMENTS

Tag	St	MaxOcc	Name
SG5	O	1	Quality complaint contact
CTA	M	1	Contact information
		EDIFACT	vitesco
Tag	Name	St Format	St Format Usage / Remark
3139	Contact function code	C an..3	R an..3 QA Quality assurance contact
C056	Contact details	C	O
3413	Contact identifier	C an..17	O an..17 Identifies the department or employee by a unique identifier other than their name when given as a contact.
3412	Contact name	C an..35	O an..35 Name of the contact person or department

Remark:

Example: CTA+QA+X:X'

MaxOcc = Maximum occurrence of the segment/group; St = Status: M=Mandatory, C=Conditional, R=Required, O=Optional, D=Dependent, A=Advised, N=Not used

3. SEGMENTS

Tag	St	MaxOcc	Name	
SG5	O	1	Quality complaint contact	
COM	O	4	Communication contact	
EDIFACT		vitesco		
Tag	Name	St	Format	Usage / Remark
C076	Communication contact	M		
3148	Communication address identifier	M	an..100	M an..100 Buyer's Communication Number
3155	Communication means type code	M	an..3	M an..3 EM Electronic mail FX Telefax IM Internal mail TE Telephone

Remark:

Example: COM+X:TE'

3. SEGMENTS

Tag	St	MaxOcc	Name			
SG2	O	1	Ship-to			
NAD	M	1	Ship-to's name and address			
			EDIFACT	vitesco		
Tag	Name	St	Format	St	Format	Usage / Remark
3035	Party function code qualifier	M	an..3	M	an..3	ST Ship to
C082	Party identification details	C		O		All partners listed in the invoicing message are to be transmitted with the complete name and address information. Partner ID is an additional information for enabling the automated processing and matching to internal records.
3039	Party identifier	M	an..35	R	an..35	In case of production materials deliveries this is usually the plant number of the receiving plant. Unique identification of a party by an ID (customer number, supplier number, DUNS or similar).
1131	Code list identification code		an..17	N		Not used
3055	Code list responsible agency code	C	an..3	R	an..3	92 Assigned by buyer or buyer's agent Agency responsible for code list / identifier maintenance
C058	Name and address			N		
3124	Name and address description	M	an..35	M	an..35	
3124	Name and address description		an..35	N		Not used
3124	Name and address description		an..35	N		Not used
3124	Name and address description		an..35	N		Not used
3124	Name and address description		an..35	N		Not used
C080	Party name	C		R		
3036	Party name	M	an..35	M	an..35	Single text line for specification of a name
3036	Party name	C	an..35	O	an..35	see 3036 # 1
3036	Party name	C	an..35	O	an..35	
3036	Party name		an..35	N		Not used
3045	Party name format code		an..3	N		Not used
C059	Street	C		O		
3042	Street and number or post office box identifier	M	an..35	M	an..35	The name that identifies the location of a house or building: usually within a street as part of an address.
3042	Street and number or post office box identifier	C	an..35	O	an..35	see 3042 # 1
3042	Street and number or post office box identifier		an..35	N		Not used
3042	Street and number or post office box identifier		an..35	N		Not used

MaxOcc = Maximum occurrence of the segment/group; St = Status: M=Mandatory, C=Conditional, R=Required, O=Optional, D=Dependent, A=Advised, N=Not used

EDIFACT			vitesco		
Tag	Name	St Format	St	Format	Usage / Remark
3164	City name	C an..35	R	an..35	The name of the city, town, or village of this address.
C819	Country subdivision details		N		
3229	Country subdivision identifier	an..9	N		Not used
1131	Code list identification code	an..17	N		Not used
3055	Code list responsible agency code	an..3	N		Not used
3228	Country subdivision name	an..70	N		Not used
3251	Postal identification code	C an..17	R	an..17	The identifier for one or more properties according to the postal service of that country; a group of letters and/or numbers added to the postal address to assist in the sorting of mail.
3207	Country identifier	C a2	R	a2	Provides the country part of an address using a code. Use ISO3166 two alpha code.

Remark:

The party to which goods are to be shipped (consigned).

Example: NAD+ST+Identifier::92++Name:Name:Name:Name+Strasse:Strasse+Ort++PLZ+DE'

3. SEGMENTS

Tag	St	MaxOcc	Name			
SG2	R	1	Seller			
NAD	M	1	Seller's name and address			
			EDIFACT	vitesco		
Tag	Name	St	Format	St	Format	Usage / Remark
3035	Party function code qualifier	M	an..3	M	an..3	SE Seller
C082	Party identification details	C		R		All partners listed in the invoicing message are to be transmitted with the complete name and address information. Partner ID is an additional information for enabling the automated processing and matching to internal records.
3039	Party identifier	M	an..35	R	an..35	Unique identification of a party by an ID (customer number, supplier number, DUNS or similar).
1131	Code list identification code		an..17	N		Not used
3055	Code list responsible agency code	C	an..3	R	an..3	92 Assigned by buyer or buyer's agent Agency responsible for code list / identifier maintenance
C058	Name and address			N		
3124	Name and address description	M	an..35	M	an..35	
3124	Name and address description		an..35	N		Not used
3124	Name and address description		an..35	N		Not used
3124	Name and address description		an..35	N		Not used
3124	Name and address description		an..35	N		Not used
C080	Party name	C		R		
3036	Party name	M	an..35	M	an..35	Single text line for specification of a name
3036	Party name	C	an..35	O	an..35	see 3036 # 1
3036	Party name	C	an..35	O	an..35	see 3036 # 1
3036	Party name	C	an..35	O	an..35	see 3036 # 1
3036	Party name		an..35	N		Not used
3045	Party name format code		an..3	N		Not used
C059	Street	C		O		
3042	Street and number or post office box identifier	M	an..35	M	an..35	The name that identifies the location of a house or building: usually within a street as part of an address.
3042	Street and number or post office box identifier	C	an..35	O	an..35	see 3042 # 1
3042	Street and number or post office box identifier		an..35	N		Not used
3042	Street and number or post office box identifier		an..35	N		Not used
3164	City name	C	an..35	O	an..35	The name of the city, town, or village of this address.
C819	Country subdivision details			N		

MaxOcc = Maximum occurrence of the segment/group; St = Status: M=Mandatory, C=Conditional, R=Required, O=Optional, D=Dependent, A=Advised, N=Not used

EDIFACT			vitesco		
Tag	Name	St Format	St	Format	Usage / Remark
3229	Country subdivision identifier	an..9	N		Not used
1131	Code list identification code	an..17	N		Not used
3055	Code list responsible agency code	an..3	N		Not used
3228	Country subdivision name	an..70	N		Not used
3251	Postal identification code	C an..17	R	an..17	The identifier for one or more properties according to the postal service of that country; a group of letters and/or numbers added to the postal address to assist in the sorting of mail.
3207	Country identifier	C a2	R	a2	Provides the country part of an address using a code. Use ISO3166 two alpha code.

Remark:

Party selling merchandise to a buyer.

Seller: The party who has liability to fulfill the contract. It is often used in the sense of seller and supplier and ship-from.

Example: NAD+SE+Identifier::92++Name:Name:Name:Name+Strasse:Strasse+Ort++PLZ+DE'

3. SEGMENTS

Tag	St	MaxOcc	Name
SG3	O	1	Seller's tax payer's number
RFF	M	1	Sellers's reference number(s)
EDIFACT		vitesco	
Tag	Name	St Format	St Format Usage / Remark
C506	Reference	M	M
1153	Reference code qualifier	M an..3	M an..3
1154	Reference identifier	C an..35	R an..35
1156	Document line identifier	an..6	N
1056	Version identifier	an..9	N
1060	Revision identifier	an..6	N

Remark:

Example: RFF+FC:Steuernummer'

MaxOcc = Maximum occurrence of the segment/group; St = Status: M=Mandatory, C=Conditional, R=Required, O=Optional, D=Dependent, A=Advised, N=Not used

3. SEGMENTS

Tag	St	MaxOcc	Name
SG3	O	1	Seller's VAT reference number(s)
RFF	M	1	Sellers's reference number(s)
EDIFACT			vitesco
Tag	Name	St Format	St Format Usage / Remark
C506	Reference	M	M
1153	Reference code qualifier	M an..3	M an..3
1154	Reference identifier	C an..35	R an..35
1156	Document line identifier	an..6	N
1056	Version identifier	an..9	N
1060	Revision identifier	an..6	N

Remark:

Example: RFF+VA:Umsatzsteuernummer des Verkäufers'

MaxOcc = Maximum occurrence of the segment/group; St = Status: M=Mandatory, C=Conditional, R=Required, O=Optional, D=Dependent, A=Advised, N=Not used

3. SEGMENTS

Tag	St	MaxOcc	Name
SG5	O	1	Information contact Information that identifies the contact person or department on general matters, together with information about how they can be contacted.
CTA	M	1	Information contact
		EDIFACT	vitesco
Tag	Name	St Format	St Format Usage / Remark
3139	Contact function code	C an..3	C an..3 IC Information contact
C056	Contact details	C	O
3413	Contact identifier	C an..17	O an..17 Identifies the department or employee by a unique identifier other than their name when given as a contact.
3412	Contact name	C an..35	O an..35 Name of the contact person or department

Remark:

Information that identifies the contact person or department on general matters, together with information about how they can be contacted.

Example: CTA+IC+:Name '

3. SEGMENTS

Tag	St	MaxOcc	Name
SG5	O	1	Information contact Information that identifies the contact person or department on general matters, together with information about how they can be contacted.
COM	O	5	Communication contact
		EDIFACT	vitesco
Tag	Name	St Format	St Format Usage / Remark
C076	Communication contact	M	M
3148	Communication address identifier	M an..100	M an..100 Communication number / address
3155	Communication means type code	M an..3	M an..3 TE Telephone FX Telefax EM Electronic mail IM Internal mail

Remark:

Example: COM+Telefonnummer:TE'

3. SEGMENTS

Tag	St	MaxOcc	Name
SG7	R	1	Invoice and payment currency
CUX	M	1	Currencies
EDIFACT			vitesco
Tag	Name	St Format	St Format Usage / Remark
C504	Invoice currency	C	C
6347	Currency usage code qualifier	M an..3	M an..3
6345	Currency identification code	C an..3	R an..3
6343	Currency type code qualifier	C an..3	R an..3
6348	Currency rate	n..4	N
C504	Home or payment currency	C	O
6347	Currency usage code qualifier	M an..3	M an..3
6345	Currency identification code	C an..3	R an..3
6343	Currency type code qualifier	C an..3	R an..3
6348	Currency rate	n..4	N
5402	Currency exchange rate	C n..12	O n..12
6341	Exchange rate currency market identifier	an..3	N

Remark:

A segment group combining a (source) currency and a target currency with the appropriate rate of exchange for those cases, where the transformation of currency is necessary.

If the invoicing currency is the official domestic currency, this segment group can be omitted (this may depend on national fiscal requirements). Otherwise it is used to state the necessary currencies.

It has to contain the invoice currency and may contain home or payment currency.
 Invoicing currency is always to be given in the first occurrence of the CUX segment, C504#1 as follows:
 6347: '2', 6345: currency, 6343: '4'

If a different payment or home currency is to be given, the second occurrence of C504 in the CUX segment is to be used as follows:
 second 6347: '3', second 6345: currency, and second 6343: '3' or '11'. Data element 5402 contains the currency conversion rate.

If three currencies have to be transmitted, another SG7 - CUX, DTM has to be created and the following rule shall apply:
 SG7#1 CUX C504#1: invoice currency (see above)
 SG7#1 CUX C504#2: payment currency (see above)
 SG7#2 CUX C504#1: home currency (see below)
 6347 '3' 6345 Currency 6343 '3'

Home currency: in some countries it is a requirement that, for invoicing in foreign currency, the invoice taxable and tax (e.g. VAT)

MaxOcc = Maximum occurrence of the segment/group; St = Status: M=Mandatory, C=Conditional, R=Required, O=Optional, D=Dependent, A=Advised, N=Not used

amounts must also be expressed in home currency. Relating this to the CUX segments, authorities would require the invoicing currency and the home currency to be shown, together with the rate of exchange (element 5402).

Example: CUX+2:EUR:4+3:USD:11+1'

3. SEGMENTS

Tag	St	MaxOcc	Name
SG7	R	1	Invoice and payment currency
DTM	D	1	Exchange rate date
		EDIFACT	vitesco
Tag	Name	St Format	St Format Usage / Remark
C507	Date/time/period	M	M
2005	Date or time or period function code qualifier	M an..3	M an..3
2380	Date or time or period text	C n8	R n8
2379	Date or time or period format code	C an..3	R an..3
			134 Rate of exchange date/time
			To specify the date a given exchange rate between two currencies has been calculated (or has been published by other sources).
			102 CCYYMMDD

Remark:

The exchange rate date has to be specified only when payment or home currency is used in that CUX segment.

Example: DTM+134:20131128:102'

MaxOcc = Maximum occurrence of the segment/group; St = Status: M=Mandatory, C=Conditional, R=Required, O=Optional, D=Dependent, A=Advised, N=Not used

3. SEGMENTS

Tag	St	MaxOcc	Name	
SG7	O	1	Home currency	
CUX	M	1	Home currency	
EDIFACT		vitesco		
Tag	Name	St Format	St Format Usage / Remark	
C504	Currency details	C	R	
6347	Currency usage code qualifier	M an..3	M an..3	3 Target currency
6345	Currency identification code	C an..3	R an..3	Code specifying a monetary unit.
6343	Currency type code qualifier	C an..3	R an..3	3 Home currency
6348	Currency rate	n..4	N	Not used
C504	Currency details		N	
6347	Currency usage code qualifier	an..3	N	Not used
6345	Currency identification code	C an..3	C an..3	
6343	Currency type code qualifier	C an..3	C an..3	
6348	Currency rate	n..4	N	Not used
5402	Currency exchange rate	C n..12	O n..12	Exchange rate between the invoice currency and the home(domestic) currency.
6341	Exchange rate currency market identifier	an..3	N	Not used

Remark:

In some countries it is a requirement that, for invoicing in foreign currency, the invoice taxable and tax (e.g. VAT) amounts must also be expressed in home currency. Relating this to the CUX segments, authorities would require the invoicing currency and the home currency to be shown, together with the rate of exchange (element 5402).

Invoicing currency is always to be given in the first occurrence of the CUX segment.

Example: CUX+3:HUF:3++1'

3. SEGMENTS

Tag	St	MaxOcc	Name
SG7	O	1	Home currency
DTM	O	1	Exchange rate date
EDIFACT		vitesco	
Tag	Name	St Format	St Format Usage / Remark
C507	Date/time/period	M	M
2005	Date or time or period function code qualifier	M an..3	M an..3
2380	Date or time or period text	C n8	O n8
2379	Date or time or period format code	C an..3	R an..3
			134 Rate of exchange date/time
			To specify the date, a given exchange rate between two currencies has been calculated (or has been published by other sources).
			102 CCYYMMDD

Remark:

This exchange rate date has to be specified only when it differs from the exchange rate date given in the previous segment group.

Example: DTM+134:::102'

MaxOcc = Maximum occurrence of the segment/group; St = Status: M=Mandatory, C=Conditional, R=Required, O=Optional, D=Dependent, A=Advised, N=Not used

3. SEGMENTS

Tag	St	MaxOcc	Name			
SG8	O	10	Payment instructions			
PYT	M	1	Payment terms			
EDIFACT			vitesco			
Tag	Name	St	Format	St	Format	Usage / Remark
4279	Payment terms type code qualifier	M	an..3	M	an..3	1 Basic Qualifier for payment terms.
C019	Payment terms			N		
4277	Payment terms description identifier		an..17	N		Not used
1131	Code list identification code		an..17	N		Not used
3055	Code list responsible agency code		an..3	N		Not used
4276	Payment terms description		an..35	N		Not used
2475	Event time reference code		an..3	N		Payment Time Reference Coded - see code list 2475 Reference to the date of a specific event, e.g. issue date of a specified business document (for example invoice date). see code list 2475 Not used
2009	Terms time relation code		an..3	N		1 Reference date 2 Before reference 3 After reference 4 End of 10-day period containing the reference date 5 End of 2-week period containing the reference date 6 End of month containing the reference date 8 End of quarter containing the reference date 9 End of year containing the reference date 12 End of half year containing the reference date Code relating terms to a reference date, time or period. Not used
2151	Period type code	C	an..3	O	an..3	D Day Code identifying a period
2152	Period count quantity	C	n..3	O	n..3	Actual number of periods (days, weeks etc.) belonging to a payment term.

Remark:

Example: PYT+1+++D+2'

MaxOcc = Maximum occurrence of the segment/group; St = Status: M=Mandatory, C=Conditional, R=Required, O=Optional, D=Dependent, A=Advised, N=Not used

3. SEGMENTS

Tag	St	MaxOcc	Name
SG8	O	10	Payment instructions
DTM	O	1	Payment due date

EDIFACT			vitesco		
Tag	Name	St Format	St	Format	Usage / Remark
C507	Date/time/period	M	M		
2005	Date or time or period function code qualifier	M an..3	M	an..3	140 Payment due date
2380	Date or time or period text	C n8	R	n8	Date when the payment is due in order to comply with the specified payment terms.
2379	Date or time or period format code	C an..3	R	an..3	102 CCYYMMDD

Remark:

This segment can be used in conjunction with any of the applicable qualifiers in the leading PYT segment.

Example: DTM+140:20131128:102'

MaxOcc = Maximum occurrence of the segment/group; St = Status: M=Mandatory, C=Conditional, R=Required, O=Optional, D=Dependent, A=Advised, N=Not used

3. SEGMENTS

Tag	St	MaxOcc	Name
SG8	O	10	Payment instructions
DTM	O	1	Reference date/time
EDIFACT		vitesco	
Tag	Name	St Format	St Format Usage / Remark
C507	Date/time/period	M	M
2005	Date or time or period function code qualifier	M an..3	M an..3 171 Reference date/time
2380	Date or time or period text	C n8	R n8 Date, the referenced document was issued, usually the invoice issue date
2379	Date or time or period format code	C an..3	R an..3 102 CCYYMMDD

Remark:

The reference date is related to data element 2009 or code ZZZ in DE 2475 in the previous PYT segment. If data element 2009 is filled, this reference date has to be specified.

Example: DTM+171:20131128:102'

MaxOcc = Maximum occurrence of the segment/group; St = Status: M=Mandatory, C=Conditional, R=Required, O=Optional, D=Dependent, A=Advised, N=Not used

3. SEGMENTS

Tag	St	MaxOcc	Name
SG8	O	10	Payment instructions
PCD	D	1	Discount, payment or instalment percentage

EDIFACT			vitesco		
Tag	Name	St Format	St	Format	Usage / Remark
C501	Percentage details	M	M		
5245	Percentage type code qualifier	M an..3	M	an..3	Payment Variation Qualifier 7 Percentage of invoice 12 Discount 122 Percentage of total payment Code 7 must be used in conjunction with code 262 in the following MOA segment, DE 5025. Code 12 must be used in conjunction with code 52 in MOA, DE 5025. Code 122 requires code 77 in the MOA segment. Code 122 is used to indicate the percentages of the total payment that is covered by the payment means, which is specified in the triggering PYT segment.
5482	Percentage	C n..10	R	n..10	Amount expressed as a percentage deductible from the total amount due if payment takes place within a specified period or before the fixed due date. Percentage of an (e.g. invoice) total amount - used to specify e.g. payment variations or instalment payments. Amount expressed as a percentage added to the total amount due for payment.
5249	Percentage basis identification code	an..3	N		Not used
1131	Code list identification code	an..17	N		Not used
3055	Code list responsible agency code	an..3	N		Not used
4405	Status description code	an..3	N		Not used

Remark:

This segment specifies - dependent on qualifier of leading PYT segment - the discount percentage or the percentage of an invoice amount that an instalment is based on. The following MOA segment has to match this percentage, if given.

UK: Present HM Customs rules are that where invoice discounts (PYT/4279 = "22") are offered, based on a percentage of the invoice, then the percentage rate must also be explicitly declared - in such cases, the optional PCD segment would be mandatory for UK invoicing purposes. Please note also that, where (settlement) discounts are allowed, the VAT on the invoice is based on the discounted invoice amounts, irrespective of whether the terms of the discount are actually taken up by the Buyer.

Example: PCD+7:5'

MaxOcc = Maximum occurrence of the segment/group; St = Status: M=Mandatory, C=Conditional, R=Required, O=Optional, D=Dependent, A=Advised, N=Not used

3. SEGMENTS

Tag	St	MaxOcc	Name			
SG8	O	10	Payment instructions			
MOA	O	1	Instalment or payment discount amount			
EDIFACT			vitesco			
Tag	Name	St	Format	St	Format	Usage / Remark
C516	Monetary amount	M		M		
5025	Monetary amount type code qualifier	M	an..3	M	an..3	52 Discount amount 262 Instalment amount
5004	Monetary amount	C	n..15	R	n..15	Value of a discount amount in currency units Value of an instalment monetary amount in currency units Value of a penalty monetary amount in currency units
6345	Currency identification code	C	an..3	R	an..3	Code specifying a monetary unit.
6343	Currency type code qualifier		an..3	N		Not used
4405	Status description code		an..3	N		Not used

Remark:

Example: MOA+52:67:EUR'

3. SEGMENTS

Tag	St	MaxOcc	Name
SG8	O	10	Payment instructions
MOA	D	1	Monetary amount
EDIFACT		vitesco	
Tag	Name	St Format	St Format Usage / Remark
C516	Monetary amount	M	M
5025	Monetary amount type code qualifier	M an..3	M an..3
5004	Monetary amount	C n..35	R n..35
6345	Currency identification code	C an..3	O an..3
6343	Currency type code qualifier	an..3	N
4405	Status description code	an..3	N

Remark:

Example: MOA+372:9:EUR'

MaxOcc = Maximum occurrence of the segment/group; St = Status: M=Mandatory, C=Conditional, R=Required, O=Optional, D=Dependent, A=Advised, N=Not used

3. SEGMENTS

Tag	St	MaxOcc	Name			
SG8	O	10	Payment instructions			
PAI	D	1	Payment instructions			
EDIFACT		vitesco				
Tag	Name	St	Format	St	Format	Usage / Remark
C534	Payment instruction details	M		M		
4439	Payment conditions code		an..3	N		Not used
4431	Payment guarantee means code		an..3	N		Not used
4461	Payment means code	C	an..3	R	an..3	49 Direct debit
1131	Code list identification code		an..17	N		Not used
3055	Code list responsible agency code		an..3	N		Not used
4435	Payment channel code		an..3	N		Not used

Remark:

Example: PAI+:::49'

3. SEGMENTS

Tag	St	MaxOcc	Name
SG8	O	10	Payment instructions
FII	O	1	Financial institution information

EDIFACT			vitesco		
Tag	Name	St Format	St	Format	Usage / Remark
3035	Party function code qualifier	M an..3	M	an..3	RH Seller's financial institution BI Buyer's financial institution
C078	Account holder identification	C	R		
3194	Account holder identifier	C an..35	R	an..35	IBAN / Account number at the financial institution where this account is held.
3192	Account holder name	C an..35	O	an..35	Name of the official account holder, as registered with a financial institution.
3192	Account holder name	C an..35	O	an..35	
6345	Currency identification code	an..3	N		Not used
C088	Institution identification	C	O		Details to identify or reference a financial institution according to legal and business requirements.
3433	Institution name code	C an..11	O	an..11	Bank identifier as assigned by S.W.I.F.T. organisation.
1131	Code list identification code	an..17	N		Not used
3055	Code list responsible agency code	C an..3	O	an..3	17 S.W.I.F.T.
3434	Institution branch identifier	C an..17	O	an..17	A unique number allocated to identify a financial institution.
1131	Code list identification code	C an..17	O	an..17	Identifier of a code list, assigned by the responsible organisation or agency
3055	Code list responsible agency code	C an..3	O	an..3	Agency responsible for code list / identifier maintenance
3432	Institution name	C an..70	O	an..70	The name of the financial institution
3436	Institution branch location name	an..70	N		Not used
3207	Country identifier	an..3	N		Not used

Remark:

Example: FII+RH+4433221100:Iron Parts Ltd.:Kontoinhaber2+:::10090000::131:Volksbank'

MaxOcc = Maximum occurrence of the segment/group; St = Status: M=Mandatory, C=Conditional, R=Required, O=Optional, D=Dependent, A=Advised, N=Not used

3. SEGMENTS

Tag	St	MaxOcc	Name
SG26	R	900	Line item section
LIN	M	1	Line item and article number

EDIFACT			vitesco		
Tag	Name	St Format	St	Format	Usage / Remark
1082	Line item identifier	C n..6	R	n..6	Sequential number generated by the sender to identify a line item within a message. It is recommended to start with value 1 and to increment by 1 for each new line.
1229	Action code	an..3	N		Not used
C212	Item number identification	C	O		
7140	Item identifier	C an..35	R	an..35	Information directly relating to the identification of an article by the buyer's identification system. Note: The term article is synonymous to the term item. In the global joint automotive guidelines the term article is used.
7143	Item type identification code	C an..3	R	an..3	IN Buyer's item number
1131	Code list identification code	an..17	N		Not used
3055	Code list responsible agency code	an..3	N		Not used
C829	Sub-line information		N		
5495	Sub-line indicator code	an..3	N		Not used
1082	Line item identifier	an..6	N		Not used
1222	Configuration level number	n..2	N		Not used
7083	Configuration operation code	an..3	N		Not used

Remark:

Line item level of an invoice document.

Example: LIN+1+++1234:IN'

3. SEGMENTS

Tag	St	MaxOcc	Name
SG26	R	900	Line item section
PIA	O	1	Additional article identifier(s) 1
		EDIFACT	vitesco
Tag	Name	St Format	St Format Usage / Remark
4347	Product identifier code qualifier	M an..3	M an..3 1 Additional identification
C212	Sellers Article Number	M	M
7140	Item identifier	C an..35	R an..35 Information directly relating to the identification of an item by the seller's identification system. Note: The term article is synonymous to the term item. In the global joint automotive guidelines the term article is used.
7143	Item type identification code	C an..3	R an..3 SA Supplier's article number
1131	Code list identification code	an..17	N Not used
3055	Code list responsible agency code	an..3	N Not used
C212	Item number identification		N
7140	Item identifier	an..35	N Not used
7143	Item type identification code	an..3	N Not used
1131	Code list identification code	an..17	N Not used
3055	Code list responsible agency code	an..3	N Not used
C212	Item number identification		N
7140	Item identifier	an..35	N Not used
7143	Item type identification code	an..3	N Not used
1131	Code list identification code	an..17	N Not used
3055	Code list responsible agency code	an..3	N Not used
C212	Item number identification		N
7140	Item identifier	an..35	N Not used
7143	Item type identification code	an..3	N Not used
1131	Code list identification code	an..17	N Not used
3055	Code list responsible agency code	an..3	N Not used
C212	Item number identification		N
7140	Item identifier	an..35	N Not used
7143	Item type identification code	an..3	N Not used
1131	Code list identification code	an..17	N Not used
3055	Code list responsible agency code	an..3	N Not used

MaxOcc = Maximum occurrence of the segment/group; St = Status: M=Mandatory, C=Conditional, R=Required, O=Optional, D=Dependent, A=Advised, N=Not used

EDIFACT			vitesco	
Tag	Name	St Format	St Format	Usage / Remark
	code			

Remark:

Example: PIA+1+9876:SA'

3. SEGMENTS

Tag	St	MaxOcc	Name			
SG26	R	900	Line item section			
IMD	R	5	Description of article or service			
EDIFACT			vitesco			
Tag	Name	St	Format	St	Format	Usage / Remark
7077	Description format code		an..3	N		Not used
C272	Item characteristic			N		
7081	Item characteristic code		an..3	N		Not used
1131	Code list identification code		an..17	N		Not used
3055	Code list responsible agency code		an..3	N		Not used
C273	Item description	C		R		
7009	Item description code		an..17	N		Not used
1131	Code list identification code		an..17	N		Not used
3055	Code list responsible agency code		an..3	N		Not used
7008	Item description	C	an..256	R	an..256	The short name or description of an article or service in plain text.
7008	Item description		an..256	N		Not used
3453	Language name code		an..3	N		Not used
7383	Surface or layer code		an..3	N		Not used

Remark:

Example: IMD+++:::Article description'

3. SEGMENTS

Tag	St	MaxOcc	Name			
SG26	R	900	Line item section			
QTY	R	1	Invoiced quantity			
EDIFACT			vitesco			
Tag	Name	St	Format	St	Format	Usage / Remark
C186	Quantity details	M		M		
6063	Quantity type code qualifier	M	an..3	M	an..3	47 Invoiced quantity
6060	Quantity	M	n..15	M	n..15	Invoiced quantity value
6411	Measurement unit code	C	an..3	R	an..3	Code specifying the unit of measurement.

Remark:

The quantity invoiced is necessary for line items belonging to an invoice, credit or debit note.

Example: QTY+47:9:C62'

3. SEGMENTS

Tag	St	MaxOcc	Name
SG26	R	900	Line item section
ALI	O	1	Country of origin, customs information and booking key

EDIFACT			vitesco		
Tag	Name	St Format	St	Format	Usage / Remark
3239	Country of origin identifier	C a2	O	a2	Country Of Origin Coded: Country in which goods have been produced or manufactured, according to criteria laid down for the purposes of application of the customs tariff, quantitative restrictions, etc.
9213	Duty regime type code	C an..3	O	an..3	A statement of the full/preferential regime according to which duty is assessed. This indicator is being used to determine the appropriate customs duty. The appropriate preference declaration to all items with the code 'Y' is to be given in the invoice header, FTX+CUS.
4183	Special condition code	C an..3	O	an..3	This data element can be used to indicate the booking key that is used for the line item in self billed invoice scenarios. 67 Delivery with change of ownership 69 Supply for consignment 140 Return of goods
4183	Special condition code	an..3	N		Not used
4183	Special condition code	an..3	N		Not used
4183	Special condition code	an..3	N		Not used
4183	Special condition code	an..3	N		Not used

Remark:

Example: ALI++N+67'

3. SEGMENTS

Tag	St	MaxOcc	Name
SG26	R	900	Line item section
DTM	D	1	Delivery or service completion date
EDIFACT		vitesco	
Tag	Name	St Format	St Format Usage / Remark
C507	Date/time/period	M	M
2005	Date or time or period function code qualifier	M an..3	M an..3
2380	Date or time or period text	C n..12	R n..12
2379	Date or time or period format code	C an..3	R an..3
1 Service completion date/time, actual			
Service completion date			
102 CCYYMMDD			

Remark:

If the line items of an invoice have different delivery or service completion dates, then this date has to be given for each line item. The delivery date on header level contains the last delivery date and is relevant for the allocation of the taxes to a tax period.

Example: DTM+1:20100308:102'

MaxOcc = Maximum occurrence of the segment/group; St = Status: M=Mandatory, C=Conditional, R=Required, O=Optional, D=Dependent, A=Advised, N=Not used

3. SEGMENTS

Tag	St	MaxOcc	Name			
SG26	R	900	Line item section			
FTX	O	99	Tax exemption reason text			
EDIFACT			vitesco			
Tag	Name	St	Format	St	Format	Usage / Remark
4451	Text subject code qualifier	M	an..3	M	an..3	TXD Tax declaration
4453	Free text function code		an..3	N		Not used
C107	Text reference			N		
4441	Free text description code		an..17	N		Not used
1131	Code list identification code		an..17	N		Not used
3055	Code list responsible agency code		an..3	N		Not used
C108	Text literal	C		R		
4440	Free text	M	an..256	M	an..256	Tax exemption reason text (reference to the provision in the EU directive in text)
4440	Free text	C	an..256	O	an..256	See DE 4440 #1
4440	Free text	C	an..256	O	an..256	See DE 4440 #1
4440	Free text	C	an..256	O	an..256	See DE 4440 #1
4440	Free text	C	an..256	O	an..256	See DE 4440 #1
3453	Language name code	C	an..3	O	an..3	Code specifying the language name. Use ISO 639-1988
4447	Free text format code		an..3	N		Not used

Remark:

Example: FTX+TXD+++X:X:X:X+aa'

MaxOcc = Maximum occurrence of the segment/group; St = Status: M=Mandatory, C=Conditional, R=Required, O=Optional, D=Dependent, A=Advised, N=Not used

3. SEGMENTS

Tag	St	MaxOcc	Name
SG27	R	1	Line item net amount
MOA	M	1	Line item net amount in invoice currency
EDIFACT		vitesco	
Tag	Name	St Format	St Format Usage / Remark
C516	Monetary amount	M	M
5025	Monetary amount type code qualifier	M an..3	M an..3
5004	Monetary amount	C n..15	R n..15
6345	Currency identification code	C an..3	R an..3
6343	Currency type code qualifier	an..3	N
4405	Status description code	an..3	N

Remark:

The line item amount is the total related to this line item. It includes rebates and additions but excludes payment discount and VAT. Calculation formula: Net price amount * invoiced quantity = (invoiced quantity * gross price) plus / minus allowances or charges.

Example: MOA+203:9:EUR'

3. SEGMENTS

Tag	St	MaxOcc	Name	
SG29	O	1	Calculation gross price	
PRI	M	1	Price details	
EDIFACT		vitesco		
Tag	Name	St Format	St Format Usage / Remark	
C509	Price information	C	R	
5125	Price code qualifier	M an..3	M an..3	AAB Calculation gross
5118	Price amount	C n..15	R n..15	Unit gross price amount in price currency units
5375	Price type code	an..3	N	Not used
5387	Price specification code	C an..3	O an..3	CON Contract price The contract price is considered to be the standard gross price. AAL and ABM are used for retrospective price adjustments.
5284	Unit price basis quantity	C n..9	O n..9	Basis on which the unit price/rate applies.
6411	Measurement unit code	C an..3	O an..3	Code specifying the unit of measurement.
5213	Sub-line item price change operation code	an..3	N	Not used

Remark:

Price without allowances and charges, this represents the gross price applicable to the line, but does not include any allowances/charges that may be applicable to the line and which are deductible from the gross price.

Example: PRI+AAB:9::AAL::KGM'

3. SEGMENTS

Tag	St	MaxOcc	Name			
SG30	O	1	Frame contract (blanket order) / Order / Purchase order			
RFF	M	1	Frame contract (blanket order) / Order / Purchase order			
EDIFACT			vitesco			
Tag	Name	St	Format	St	Format	Usage / Remark
C506	Reference	M		M		
1153	Reference code qualifier	M	an..3	R	an..3	ON Order document identifier, buyer assigned Type of reference, coded In the context of this VDA recommendation the codes are to be interpreted as follows: ON = Frame contract (blanket order) / Order / Purchase order
1154	Reference identifier	C	an..35	R	an..35	Unique identifier of the referenced document
1156	Document line identifier	C	n..6	O	n..6	Sequential number generated by the sender to identify a line item within a message. It is recommended to start with value 1 and to increment by 1 for each new line.
1056	Version identifier		an..9	N		Not used
1060	Revision identifier		an..6	N		Not used

Remark:

Example: RFF+ON:Bestellnummer:1'

3. SEGMENTS

Tag	St	MaxOcc	Name	
SG30	O	1	Despatch note / delivery note (synonym) Belegnummer WE auf Abrechnungs-LP	
RFF	M	1	Reference message number	
		EDIFACT	vitesco	
Tag	Name	St Format	St Format Usage / Remark	
C506	Reference	M	M	
1153	Reference code qualifier	M an..3	R an..3	AAU Despatch note document identifier Type of reference, coded
1154	Reference identifier	C an..35	R an..35	Unique identifier of the referenced document
1156	Document line identifier	C n..6	O n..6	Sequential number generated by the sender to identify a line item within a message. It is recommended to start with value 1 and to increment by 1 for each new line.
1056	Version identifier	an..9	N	Not used
1060	Revision identifier	an..6	N	Not used

Remark:

Example: RFF+AAU:Lieferscheinnummer:1'

3. SEGMENTS

Tag	St	MaxOcc	Name	
SG30	O	1	Despatch note / delivery note (synonym) Belegnummer WE auf Abrechnungs-LP	
DTM	O	1	Reference message date	
EDIFACT		vitesco		
Tag	Name	St Format	St Format Usage / Remark	
C507	Date/time/period	M	M	
2005	Date or time or period function code qualifier	M an..3	M an..3	171 Reference date/time
2380	Date or time or period text	C n..12	R n..12	Reference Document Date/Time
2379	Date or time or period format code	C an..3	R an..3	102 CCYYMMDD

Remark:

Example: DTM+171:20131120:102'

3. SEGMENTS

Tag	St	MaxOcc	Name	
SG30	O	1	Goods receipt number / consignment withdrawal or aggregation number	
RFF	M	1	Reference message number	
		EDIFACT	vitesco	
Tag	Name	St Format	St Format Usage / Remark	
C506	Reference	M	M	ALO Receiving advice number Type of reference, coded
1153	Reference code qualifier	M an..3	R an..3	
1154	Reference identifier	C an..35	R an..35	Unique identifier of the referenced document
1156	Document line identifier	C n..6	O n..6	Sequential number generated by the sender to identify a line item within a message. It is recommended to start with value 1 and to increment by 1 for each new line.
1056	Version identifier	an..9	N	Not used
1060	Revision identifier	an..6	N	Not used

Remark:

Example: RFF+ALO:Wareneingangsnummer:5'

3. SEGMENTS

Tag	St	MaxOcc	Name	
SG30	O	1	internal-order-number	
RFF	M	1	Reference message number	
		EDIFACT	vitesco	
Tag	Name	St Format	St Format Usage / Remark	
C506	Reference	M	M	
1153	Reference code qualifier	M an..3	R an..3	Type of reference, coded IL Internal order number
1154	Reference identifier	C an..35	R an..35	Unique identifier of the referenced document
1156	Document line identifier	C n..6	O n..6	Sequential number generated by the sender to identify a line item within a message. It is recommended to start with value 1 and to increment by 1 for each new line.
1056	Version identifier	an..9	N	Not used
1060	Revision identifier	an..6	N	Not used

Remark:

Example: RFF+IL:Abrechnungslieferplannummer:5'

3. SEGMENTS

Tag	St	MaxOcc	Name			
SG34	R	1	VAT rate and amount for line item			
TAX	M	1	VAT or other tax rate			
			EDIFACT	vitesco		
Tag	Name	St	Format	St	Format	Usage / Remark
5283	Duty or tax or fee function code qualifier	M	an..3	M	an..3	7 Tax Code qualifying the function of a duty or tax or fee.
C241	Duty/tax/fee type	C		R		
5153	Duty or tax or fee type name code	C	an..3	O	an..3	VAT Value added tax Code specifying a type of duty, tax or fee. Code OTH shall be used when the tax in question is not one of the listed. Code SUR is used to qualify the used part tax, which is additional to VAT (currently 10% of VAT amount due for the used part).
1131	Code list identification code		an..17	N		Not used
3055	Code list responsible agency code		an..3	N		Not used
5152	Duty or tax or fee type name		an..35	N		Not used
C533	Duty/tax/fee account detail			N		
5289	Duty or tax or fee account code		an..6	N		Not used
1131	Code list identification code		an..17	N		Not used
3055	Code list responsible agency code		an..3	N		Not used
5286	Duty or tax or fee assessment basis quantity		an..15	N		Not used
C243	Duty/tax/fee detail	C		R		
5279	Duty or tax or fee rate code		an..7	N		Not used
1131	Code list identification code		an..17	N		Not used
3055	Code list responsible agency code		an..3	N		Not used
5278	Duty or tax or fee rate	C	n..7	R	n..7	Rate (percentage) of the specified tax. The tax rate (numeric) should be presented as follows: 19.5% ==> :19.5
5273	Duty or tax or fee rate basis code		an..12	N		Not used
1131	Code list identification code		an..17	N		Not used
3055	Code list responsible agency code		an..3	N		Not used

MaxOcc = Maximum occurrence of the segment/group; St = Status: M=Mandatory, C=Conditional, R=Required, O=Optional, D=Dependent, A=Advised, N=Not used

EDIFACT			vitesco		
Tag	Name	St Format	St	Format	Usage / Remark
5305	Duty or tax or fee category code	C an..3	O	an..3	<p>Under EU directive and national law, any exemption from tax has to be declared more detailed. There are several provisions in the directive, which allow exemption. In the European environment it is necessary to state this reason whenever the invoice issuer declares an invoice item or the whole invoice to be VAT exempt.</p> <p>Code specifying a duty or tax or fee category. This code list contains codes referencing to the Sixth EU directive regarding tax exemption and special procedures. It is intended to be harmonised with other European industry organisations and finally the codes shall be added to the UN/EDIFACT code list 5305 to facilitate a homogeneous implementation of the directive's provisions throughout Europe.</p> <p>The use of any valid EDIFACT code is permitted, the trading partners may limit the codes in accordance with business and legal requirements.</p> <p>(1) Codes created to comply with the European invoicing directive. These codes are not yet part of the official EDIFACT code list.</p> <p style="text-align: center;">S Standard rate</p>
3446	Party tax identifier	an..20	N		Not used
1227	Calculation sequence code	an..3	N		Not used
5307	Tax or duty or fee payment due date code	an..3	N		Not used

Remark:

This segment group is required when VAT is calculated at the line item level. Tax identification is required at the line item level as different goods and services can be taxed at different rates. That concerns VAT as well as different intrastate or interstate tax rates in the US.

Example: TAX+7+VAT+++:::19+AA'

3. SEGMENTS

Tag	St	MaxOcc	Name			
UNS	M	1	Section control			
		EDIFACT	vitesco			
Tag	Name	St	Format	St	Format	Usage / Remark
0081	Section identification	M	a1	M	a1	S Detail/summary section separation

Remark:

Example: UNS+S'

MaxOcc = Maximum occurrence of the segment/group; St = Status: M=Mandatory, C=Conditional, R=Required, O=Optional, D=Dependent, A=Advised, N=Not used

3. SEGMENTS

Tag	St	MaxOcc	Name	
SG50	R	3	Invoice amount	
MOA	M	1	Invoice amount	
		EDIFACT	vitesco	
Tag	Name	St Format	St Format	Usage / Remark
C516	Monetary amount	M	M	
5025	Monetary amount type code qualifier	M an..3	M an..3	77 Invoice line item amount
5004	Monetary amount	C n..15	R n..15	Invoice total amount, including taxes (if applicable)
6345	Currency identification code	C an..3	R an..3	Code specifying a monetary unit.
6343	Currency type code qualifier	an..3	N	Not used
4405	Status description code	an..3	N	Not used

Remark:

Total sum charged in respect of a single invoice in accordance with the terms of delivery.
Invoice amount (MOA+77) is the sum of:
line item amounts (MOA+79)
plus total invoice additional amount (MOA+136)
plus total duty/tax/fee amount (MOA+176)

Relation between Home Currency and Invoicing Currency is established through data element 5402 (rate of exchange) in the CUX segment at header level.

Example: MOA+77:1000:EUR'

3. SEGMENTS

Tag	St	MaxOcc	Name
SG50	R	3	Total tax amount
MOA	M	1	Total tax amount
		EDIFACT	vitesco
Tag	Name	St Format	St Format Usage / Remark
C516	Monetary amount	M	M
5025	Monetary amount type code qualifier	M an..3	M an..3
5004	Monetary amount	C n..15	R n..15
6345	Currency identification code	C an..3	R an..3
6343	Currency type code qualifier	an..3	N
4405	Status description code	an..3	N
			176 Message total duty/tax/fee amount
			Value of tax amount in currency units
			Code specifying a monetary unit.
			Not used
			Not used

Remark:

Example: MOA+176:9:EUR'

MaxOcc = Maximum occurrence of the segment/group; St = Status: M=Mandatory, C=Conditional, R=Required, O=Optional, D=Dependent, A=Advised, N=Not used

3. SEGMENTS

Tag	St	MaxOcc	Name
SG50	O	3	Total line items amount
MOA	M	1	Total line items amount (sum of net line items amounts)
		EDIFACT	vitesco
Tag	Name	St Format	St Format Usage / Remark
C516	Monetary amount	M	M
5025	Monetary amount type code qualifier	M an..3	M an..3
5004	Monetary amount	C n..15	R n..15
6345	Currency identification code	C an..3	R an..3
6343	Currency type code qualifier	an..3	N
4405	Status description code	an..3	N

Remark:

Sum of all line items net amounts (MOA+203...)

Example: MOA+79:9:EUR'

MaxOcc = Maximum occurrence of the segment/group; St = Status: M=Mandatory, C=Conditional, R=Required, O=Optional, D=Dependent, A=Advised, N=Not used

3. SEGMENTS

Tag	St	MaxOcc	Name			
SG52	R	10	Tax rates and amounts			
TAX	M	1	Tax type and rate			
EDIFACT			vitesco			
Tag	Name	St	Format	St	Format	Usage / Remark
5283	Duty or tax or fee function code qualifier	M	an..3	M	an..3	7 Tax Code qualifying the function of a duty or tax or fee.
C241	Duty/tax/fee type	C		R		
5153	Duty or tax or fee type name code	C	an..3	R	an..3	VAT Value added tax Code specifying a type of duty, tax or fee. Code SUR is used to qualify the used part tax, which is additional to VAT (currently 10% of VAT amount).
1131	Code list identification code		an..17	N		Not used
3055	Code list responsible agency code		an..3	N		Not used
5152	Duty or tax or fee type name		an..35	N		Not used
C533	Duty/tax/fee account detail			N		
5289	Duty or tax or fee account code		an..6	N		Not used
1131	Code list identification code		an..17	N		Not used
3055	Code list responsible agency code		an..3	N		Not used
5286	Duty or tax or fee assessment basis quantity		an..15	N		Not used
C243	Duty/tax/fee detail	C		R		
5279	Duty or tax or fee rate code		an..7	N		Not used
1131	Code list identification code		an..17	N		Not used
3055	Code list responsible agency code		an..3	N		Not used
5278	Duty or tax or fee rate	C	n..7	R	n..7	Rate (percentage) of the specified tax. The tax rate (numeric) should be presented in an alpha-numeric field as follows: 19.5% ==> :19.5
5273	Duty or tax or fee rate basis code		an..12	N		Not used
1131	Code list identification code		an..17	N		Not used
3055	Code list responsible agency code		an..3	N		Not used
5305	Duty or tax or fee category code	C	an..3	D	an..3	Under 6th EU directive, any exemption from tax has to be declared more detailed. There are several provisions in the directive, which allow exemption. In the European environment

MaxOcc = Maximum occurrence of the segment/group; St = Status: M=Mandatory, C=Conditional, R=Required, O=Optional, D=Dependent, A=Advised, N=Not used

EDIFACT			vitesco		
Tag	Name	St Format	St	Format	Usage / Remark
					<p>it is necessary to state this reason whenever the invoice issuer declares an invoice item or the whole invoice to be VAT exempt.</p> <p>Code specifying a duty or tax or fee category.</p> <p>This code list contains codes referencing to the Sixth EU directive regarding tax exemption and special procedures. It is intended to be harmonised with other European industry organisations and finally the codes shall be added to the UN/EDIFACT code list 5305 to facilitate a homogeneous implementation of the directive's provisions throughout Europe.</p> <p>The use of any valid EDIFACT code is permitted, the trading partners may limit the codes in accordance with business and legal requirements.</p> <p>(1) Codes created to comply with the European invoicing directive. These codes are not yet part of the official EDIFACT code list. In Europe it is recommended or may be even required to use these more specific codes instead of code E.</p> <p>Recommendation:</p> <p style="text-align: center;">S Standard rate</p>
3446	Party tax identifier	an..20	N		Not used
1227	Calculation sequence code	an..3	N		Not used
5307	Tax or duty or fee payment due date code	an..3	N		Not used

Remark:

Example: TAX+7+VAT+++:::19+S'

3. SEGMENTS

Tag	St	MaxOcc	Name			
SG52	R	10	Tax rates and amounts			
MOA	R	1	Taxable amount in invoice currency			
EDIFACT		vitesco				
Tag	Name	St	Format	St	Format	Usage / Remark
C516	Monetary amount	M		M		
5025	Monetary amount type code qualifier	M	an..3	M	an..3	125 Taxable amount
5004	Monetary amount	C	n..15	R	n..15	Value of a taxable amount in currency units
6345	Currency identification code	C	an..3	R	an..3	Code specifying a monetary unit.
6343	Currency type code qualifier		an..3	N		Not used
4405	Status description code		an..3	N		Not used

Remark:

Example: MOA+125:9:EUR'

MaxOcc = Maximum occurrence of the segment/group; St = Status: M=Mandatory, C=Conditional, R=Required, O=Optional, D=Dependent, A=Advised, N=Not used

3. SEGMENTS

Tag	St	MaxOcc	Name			
SG53	D	15	Delivery costs			
ALC	M	1	Charge			
EDIFACT			vitesco			
Tag	Name	St	Format	St	Format	Usage / Remark
5463	Allowance or charge code qualifier	M	an..3	M	an..3	C Charge
C552	Allowance/charge information			N		
1230	Allowance or charge identifier		an..35	N		Not used
5189	Allowance or charge identification code		an..3	N		Not used
4471	Settlement means code		an..3	N		Not used
1227	Calculation sequence code		an..3	N		Not used
C214	Special services identification	C		R		
7161	Special service description code	C	an..3	R	an..3	ABK Miscellaneous ABM ABO ABP ABW FC Freight service FI Financing HD Handling IN PC Packing
1131	Code list identification code		an..17	N		Not used
3055	Code list responsible agency code	C	an..3	O	an..3	272 Joint Automotive Industry agency
7160	Special service description		an..35	N		Not used
7160	Special service description		an..35	N		Not used

Remark:

This segment group is used for additional charge on invoice level (e.g. freight, packaging), i.e. in addition to charges that might be stated at individual line items. It is not the sum of line item charges.

Example: ALC+C++++ABK: :272 '

MaxOcc = Maximum occurrence of the segment/group; St = Status: M=Mandatory, C=Conditional, R=Required, O=Optional, D=Dependent, A=Advised, N=Not used

3. SEGMENTS

Tag	St	MaxOcc	Name
SG53	D	15	Delivery costs
MOA	R	1	Charge amount

EDIFACT			vitesco		
Tag	Name	St Format	St	Format	Usage / Remark
C516	Monetary amount	M	M		
5025	Monetary amount type code qualifier	M an..3	M	an..3	8 Allowance or charge amount
5004	Monetary amount	C n..35	R	n..35	Charge amount
6345	Currency identification code	C an..3	R	an..3	Code specifying a monetary unit.
6343	Currency type code qualifier	an..3	N		Not used
4405	Status description code	an..3	N		Not used

Remark:

Example: MOA+8:9:EUR'

3. SEGMENTS

Tag	St	MaxOcc	Name			
SG53	D	15	Delivery costs			
FTX	O	1	Charge description text			
			EDIFACT	vitesco		
Tag	Name	St	Format	St	Format	Usage / Remark
4451	Text subject code qualifier	M	an..3	M	an..3	ALC Allowance/charge information
4453	Free text function code		an..3	N		Not used
C107	Text reference			N		
4441	Free text description code		an..17	N		Not used
1131	Code list identification code		an..17	N		Not used
3055	Code list responsible agency code		an..3	N		Not used
C108	Text literal	C		R		
4440	Free text	M	an..256	M	an..256	Additional charge description text
4440	Free text	C	an..256	O	an..256	See DE 4440 #1
4440	Free text	C	an..256	O	an..256	See DE 4440 #1
4440	Free text	C	an..256	O	an..256	See DE 4440 #1
4440	Free text	C	an..256	O	an..256	See DE 4440 #1
3453	Language name code	C	an..3	O	an..3	Code specifying the language name. Use ISO 639-1988
4447	Free text format code		an..3	N		Not used

Remark:

Example: FTX+ALC+++X:X:X:X+en'

MaxOcc = Maximum occurrence of the segment/group; St = Status: M=Mandatory, C=Conditional, R=Required, O=Optional, D=Dependent, A=Advised, N=Not used

3. SEGMENTS

Tag	St	MaxOcc	Name			
UNT	M	1	Message trailer			
EDIFACT		vitesco				
Tag	Name	St	Format	St	Format	Usage / Remark
0074	Number of segments in the message	M	n..6	M	n..6	Number of segments in the message
0062	Message reference number	M	an..14	M	an..14	

Remark:

Example: UNT+55+1'

MaxOcc = Maximum occurrence of the segment/group; St = Status: M=Mandatory, C=Conditional, R=Required, O=Optional, D=Dependent, A=Advised, N=Not used

3. SEGMENTS

Tag	St	MaxOcc	Name			
UNZ	M	1	Interchange trailer			
EDIFACT		vitesco				
Tag	Name	St	Format	St	Format	Usage / Remark
0036	Interchange control count	M	n..6	M	n..6	Number of messages in the data interchange.
0020	Interchange control reference	M	an..14	M	an..14	Repetition of the value transmitted in UNB data element 0020.

Remark:

Example: UNZ+1+144659'

4. EXAMPLE MESSAGE

No	Tag	Example
01	UNA	UNA:+.?'
02	UNB	UNB+UNOC:3+OD012345:59:123+987654321:1:X+071205:1446+144659+++++1'
03	UNH	UNH+1+INVOIC:D:07A:UN:GAVA12'
04	BGM	BGM+389:::Gutschrift+Rechnungsnummer+9'
05	DTM	DTM+137:20131126:102'
06	DTM	DTM+1:20100308:102'
07	FTX	FTX+REG+++Gutschrift:Text:Text:Text:Text+de'
08	FTX	FTX+TXD+++Text:Text:Text:Text:Text+de'
	SG2	
09	NAD	NAD+BY+Identifizier::91+Name+Name:Name:Name+Strasse:Strasse+Ort++PLZ+DE'
	SG3	
10	RFF	RFF+VA:7656444'
	SG3	
11	RFF	RFF+ADE:7656444'
	SG5	
12	CTA	CTA+IC+X:X'
13	COM	COM+X:TE'
	SG5	
14	CTA	CTA+QA+X:X'
15	COM	COM+X:TE'
	SG2	
16	NAD	NAD+ST+Identifizier::92++Name:Name:Name:Name+Strasse:Strasse+Ort++PLZ+DE'
	SG2	
17	NAD	NAD+SE+Identifizier::92++Name:Name:Name:Name+Strasse:Strasse+Ort++PLZ+DE'
	SG3	
18	RFF	RFF+FC:Steuernummer'
	SG3	
19	RFF	RFF+VA:Umsatzsteuernummer des Verkäufers'
	SG5	
20	CTA	CTA+IC+:Name'
21	COM	COM+Telefonnummer:TE'
	SG7	
22	CUX	CUX+2:EUR:4+3:USD:11+1'

No = Consecutive segment number

No	Tag	Example
23	DTM	DTM+134:20131128:102'
	SG7	
24	CUX	CUX+3:HUF:3++1'
25	DTM	DTM+134::102'
	SG8	
26	PYT	PYT+1+++D+2'
27	DTM	DTM+140:20131128:102'
28	DTM	DTM+171:20131128:102'
29	PCD	PCD+7:5'
30	MOA	MOA+52:67:EUR'
31	MOA	MOA+372:9:EUR'
32	PAI	PAI+::49'
33	FII	FII+RH+4433221100:Iron Parts Ltd.:Kontoinhaber2+:::10090000::131:Volks bank'
	SG26	
34	LIN	LIN+1++1234:IN'
35	PIA	PIA+1+9876:SA'
36	IMD	IMD+++:::Article description'
37	QTY	QTY+47:9:C62'
38	ALI	ALI++N+67'
39	DTM	DTM+1:20100308:102'
40	FTX	FTX+TXD+++X:X:X:X+aa'
	SG27	
41	MOA	MOA+203:9:EUR'
	SG29	
42	PRI	PRI+AAB:9::AAL::KGM'
	SG30	
43	RFF	RFF+ON:Bestellnummer:1'
	SG30	
44	RFF	RFF+AAU:Lieferscheinnummer:1'
45	DTM	DTM+171:20131120:102'
	SG30	
46	RFF	RFF+ALO:Wareneingangsnummer:5'
	SG30	
47	RFF	RFF+IL:Abrechnungslieferplannummer:5'
	SG34	
48	TAX	TAX+7+VAT+++:::19+AA'

No = Consecutive segment number

No	Tag	Example
49	UNS	UNS+S'
	SG50	
50	MOA	MOA+77:1000:EUR'
	SG50	
51	MOA	MOA+176:9:EUR'
	SG50	
52	MOA	MOA+79:9:EUR'
	SG52	
53	TAX	TAX+7+VAT+++:::19+S'
54	MOA	MOA+125:9:EUR'
	SG53	
55	ALC	ALC+C++++ABK:::272'
56	MOA	MOA+8:9:EUR'
57	FTX	FTX+ALC+++X:X:X:X+en'
58	UNT	UNT+55+1'
59	UNZ	UNZ+1+144659'

No = Consecutive segment number